



SADE SP-B40 Benchtop

Weight Sorter/Checkweigher for tablets and capsules

COMPACT BENCHTOP WEIGHT SORTER — Ideal for the R&D laboratory

Designed for the 100% weight sorting of small development or clinical trial batches, the compact SADE SP-B40 is ideal for the laboratory environment.

Easy to operate, product is simply loaded directly into the bowl feeder. Each tablet, or capsule, is individually weighed to a high accuracy of +/- 1mg and then sorted into accept and reject categories.

The unit handles a wide range of solid dose forms without the need for any format parts. Rapid clean down and ease of set-up means that the unit can be ready for the next product in a short time keeping down time to a minimum.

The SADE SP-B40 has the facility of fixed quantity sorting so is ideal for filling bottles with exactly the number you need.

In weight sampling mode, the SADE SP-B40 is also adept at providing statistical analysis on samples of tablets or capsules.

R&D — Ensures weight uniformity

100% weight sorting of development or clinical trial batches. Monitor the average weight of samples for QC or production purposes.

KEY FEATURES

- Sorts both tablets and capsules
- Handles different shapes and sizes
- High accuracy, +/- 1mg
- Quick and easy clean down
- Fixed quantity sorting



weight
sorting

Distributed by:

Lab Unlimited
CARL STUART GROUP

Tallaght Business Park
Whitestown
Dublin 24
Ireland

Tel: (01) 4523432
Fax: (01) 4523967
E-mail: info@labunlimited.com
Web: www.labunlimited.com

SADE SP-B40 Benchtop

Weight Sorter/Checkweigher for tablets and capsules

KEY OPERATIONAL BENEFITS

Our SADE SP units are already delivering precision weight sorting of the world's leading pharmaceutical companies around the globe.

Maximise speed and accuracy, minimise cost

- Consistent and precision weight sorting with an accuracy of +/- 1mg
- Versatile unit sorts tablets and capsules of different shapes and sizes
- No need for costly format parts and time consuming change over's
- Fast effective clean down – boosts operational efficiency
- Quick and easy batch set up via improved user interface
- Facility for fixed quantity sorting for ease of bottle filling

Informed decision making and action taking

- New touch screen provides real time display of statistical data
- Prints detailed reports directly via USB local or network printer
- Data can be transferred to your PC via SP Connect
 - enhanced reports automatically saved as secure pdf files
 - individual weights can be transferred into Excel

TECHNICAL DETAILS

Mounting	Benchtop
Weighing Channels	1
Sorting Rate	Up to 75 items per/min Varies per product and weighing environment
Bowl Capacity	Ranges between 100-600 items dependent on product size
Weight Range	0 - 2g
Product Size	Tablets: Up to 24mm length, 20mm wide Capsules: 0,1,2,3,4,5,& 00
Balance Readability	0.1 mg
Reproducibility	+/- 1mg or +/- 0.5mg
Zero System	Automatic
Contact Parts	316 electro-polished stainless steel and PEEK polyetheretheketone FDA 21 CFR 177.2415
Dimensions (mm)	See Diagram
Voltage & Frequency	115/230 VAC 50/60 Hz
Air Supply	Clean dry air 3-4 bar or 43-73PSI

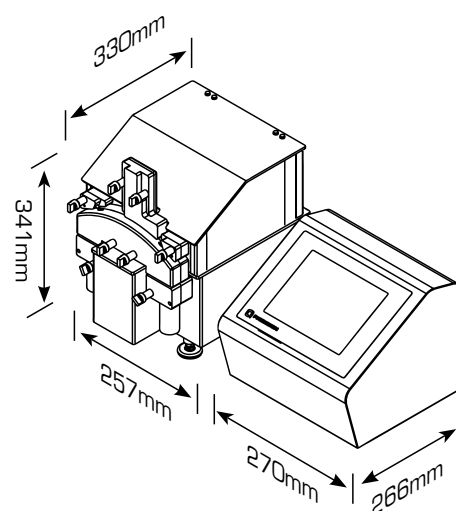

Distributed by:

Lab Unlimited
CARL STUART GROUP

Tallaght Business Park
Whitestown
Dublin 24
Ireland

Tel: (01) 4523432
Fax: (01) 4523967
E-mail: info@labunlimited.com
Web: www.labunlimited.com